

REV LTR	DESCRIPTION	DATE	APPVD.
-	Orig. Release	02/15/08	JSN
A	Revised per ECN 2012-1	11/09/12	JSN
B	Revised per ECN 2014-1	03/26/14	JSN
C	Revised per ECN 2016-2	10/21/16	JSN

FTTC11 Series
CMOS/LVDS/LVEPCL/CML Output TCXO/VCTCXO
FOR SPACE APPLICATIONS
10MHz to 1400MHz
(5 x 7 mm, SMD, 1.8V, 2.5 V,3.3V)

(Refer to Page 5 for Models with Reduced Screening & QCI)

1. SCOPE: FTTC11 series, CML output, high reliability hybrid microcircuit crystal oscillators are designed, produced and tested by Frequency Technology, Inc. as MIL-PRF-55310, Class "S" equivalent devices for use in advanced military, avionics and space applications. These devices are of hybrid microcircuit technology conforming to MIL-PRF-55310, Type 1, Class 2 oscillators.

2. APPLICABLE DOCUMENTS:

MIL-PRF-55310E	Oscillator, Crystal Controlled, General Specifications for
MIL-PRF-38534G	Hybrid Microcircuits, General Specifications for
MIL-STD-883E	Test Methods and Procedures for Microelectronics

3. REQUIREMENTS:

3.1 General: The individual item requirements shall be as specified herein.

3.2 Package: Ceramic, 90% Min. AL_2O_3 . Thermal Resistance, θ_{JC} : 50 °C / Watt.

3.2.1 Termination Finish: 1.3 μm minimum gold plate over 2.0 μm minimum nickel plate. Hot Solder tinning with Sn60/Pb40 solder per MIL-PRF-55310 is optional at an additional cost.

3.2.2 Weight: 0.30 Gms Max.

3.2.3 Reflow Soldering: Reflow soldering at 260 °C for 10 seconds shall not degrade the performance.

3.3 Hermeticity: Resistance welded, hermetically sealed, leak rate of $1(10)^{-8}$ atm-cc/s Max.

3.4. Marking: As a minimum, the parts shall be marked with Fre-tech P/N and date code

3.5 Absolute Maximum Ratings: Unless otherwise specified, absolute maximum ratings shall be as follows:

Supply Voltage	-0.5 to +4.0 VDC
Operating Free-Air Temperature Range	-55°C to +125°C
Storage Temperature	-55°C to +125°C

3.6 Electrical Characteristics: See Table I

3.6.1 Total Dose Radiation: Hybrid Microcircuit Crystal Oscillators shall be capable of meeting the electrical characteristics of Para. 3.6 after being exposed to total ionizing dose radiation of 100 krads as per MIL-STD-883, method 1019.

3.7 Hybrid Elements:

3.7.1 Quartz Crystals: High grade cultured quartz crystal shall be used. As an option, Fre-tech will use premium Q swept quartz crystal at an additional charge, refer to part numbering example in paragraph 6 to specify swept quartz crystal. Crystal element evaluation shall be in accordance with MIL-PRF-55310.

3.7.2 Crystal Mounting: Crystal element shall be mounted at 4 points in such a manner as to provide adequate ruggedness and performance under extreme environments specified herein.

- 3.7.3 Passive Elements: Established Reliability (ER) QPL components, failure level R minimum shall be used or element lot evaluation shall be as per MIL-PRF-55310, class S, or MIL-PRF-38534, Appendix C, Class K as applicable.
- 3.7.4 Microcircuit die shall be from lots that have passed the element evaluation per MIL-PRF-55310, Appendix B, Level S, except testing per Subgroup 5 is omitted. Subgroup 5 testing is circuit configuration dependent, therefore, it is more effectively performed at the oscillator level as explained in Paragraph 3.7.4 herein.
- 3.7.5 For Output Frequency up to 90 MHz, microcircuit die used in the oscillator shall be from NSC/FC 54ACT family and must be from wafer lot that has been successfully tested in the oscillator for ionizing radiation of up to 100 krad. Fre-tech has also performed SET & SEL testing on the microcircuit die. Test reports are available on request. For output frequencies above 90 MHz, the microcircuit die shall be from 0,8 μm BiCMOS Si family and must be from wafer lots that have been successfully tested in the oscillator for ionizing radiation of up to 100Krad and is known to be Single Event Latch-up immune for LET of up to 95 Mev-cm²/mg.
- 3.7.6 Workmanship, Rework and Process controls shall be in accordance with the requirements of MIL-PRF-55310.
- 3.7.7 Lot Traceability: Production lot for these oscillators shall be homogenous. Each element used in the production lot shall be traceable to a single lot. Swept quartz shall be traceable to the quartz bar, and its applicable processing details.

4. Quality Assurance Provisions: The quality assurance provisions shall be per MIL-PRF-55310, except as specified herein.

4.1 100% Screening: The 100% screening shall be performed as per Table II. PDA requirements for nondestructive bond pull and burn-in shall be as specified below.

4.2 PDA for Nondestruct Bond Pull: Unless otherwise specified, PDA shall be 2% of total number of wires or 1 wire whichever is greater.

4.3 PDA for Burn-in: Unless otherwise specified, PDA for burn-in shall be 2% or 1 oscillator whichever is greater and shall be applicable to +23 °C and/or +25 °C static tests only. In addition Delta Calculation shall be performed after Burn-in and shall count for PDA. All measured values for Delta Calculation shall be recorded. Parts that exceed the specified delta limits shall be rejected and be counted for PDA. Delta Calculation shall be performed at 3.3 VDC for the following parameters:

Input Current	10% change Maximum
Output High Level	10% change Maximum
Output Low Level	0.1V change Maximum

4.4 Group A inspection shall be in accordance with MIL-PRF-55310 for product level S.

4.5 Group B inspection (30 day aging) shall be in accordance with MIL-PRF-55310 for product level S. In order to expedite delivery, by customer request, the aging test can be ended after 15 days if the amount of frequency aging is less than 50% of the 30 day specification limit.

4.6 Oscillators shall be capable of meeting group C inspection per MIL-PRF-55310. Generic group C inspection data on similar parts may be used to satisfy this requirement. When specified by the Customer, Fre-tech will perform Group C testing at an additional charge.

4.7 Inspection and Test Data: Unless otherwise specified in the purchase order, the following Inspection and test data documentation shall be supplied with the parts.

Certificate of Conformance
Summary of Class "S" screening Test Results
PDA Calculations for Non-Destruct Bond Pull and Burn-in
Summary of Elements Lot Traceability
Electrical Tests before and after Burn-in
Group A Inspection Summary
Group B (30 day Aging) Data
Radiographic Inspection Certificate

4.8 The following test and inspection options are available at customer request.

Customer Source Inspection for Pre-Cap and Final
Group C Inspection per MIL-PRF-55310 on 4 or 8 units
DPA (Destructive Physical Analysis)
Life Test per MIL-STD-883, Method 1005, 1000 Hrs. at +125 °C
MIL-PRF-38534, Group B Inspection
MIL-PRF-38534, Group C Inspection

5.0 Preservation, Packaging and Packing: The oscillators shall be clean, dry and packaged in a manner to provide adequate protection against electrostatic discharge, corrosion, deterioration and physical damage during shipment.

6.0 How to order:

Product Dimension:

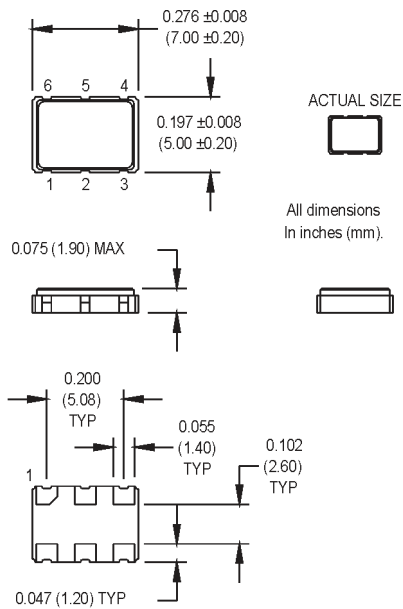

Pin connections:

LVPECL, LVDS, CML

Pin #	Connection
1	N/C or Vc
2	N/C
3	GND
4	Output
5	Output
6	Supply Voltage

SUGGESTED SOLDER PAD LAYOUT

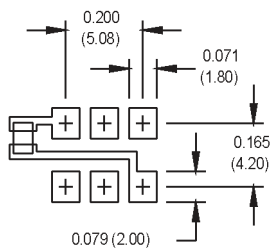

CMOS

Pin #	Connection
1	N/C or Vc
2	N/C
3	GND
4	Output
5*	N/C
6	Supply Voltage

Output Waveform

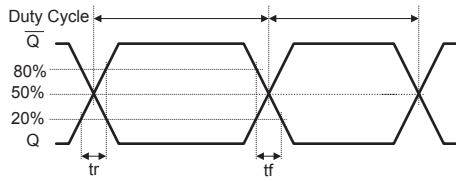

Suggested Pad Layout

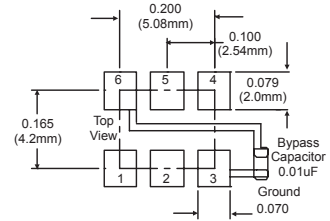

Typical Test Circuit & Load Circuit Diagrams

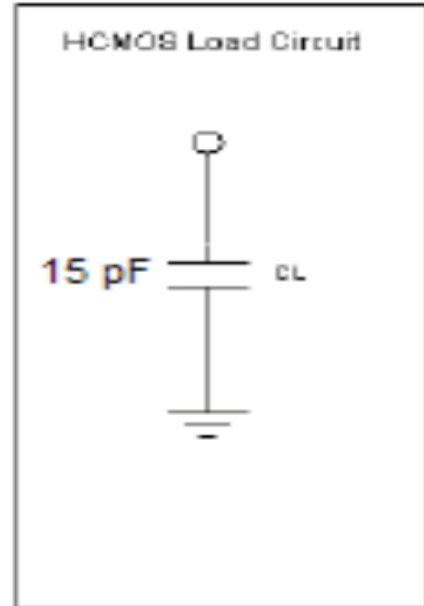
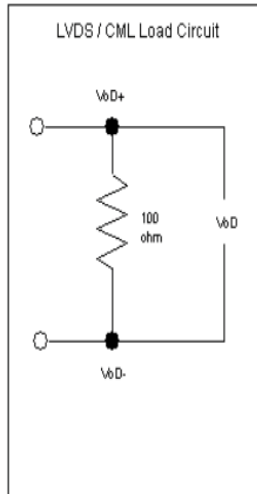
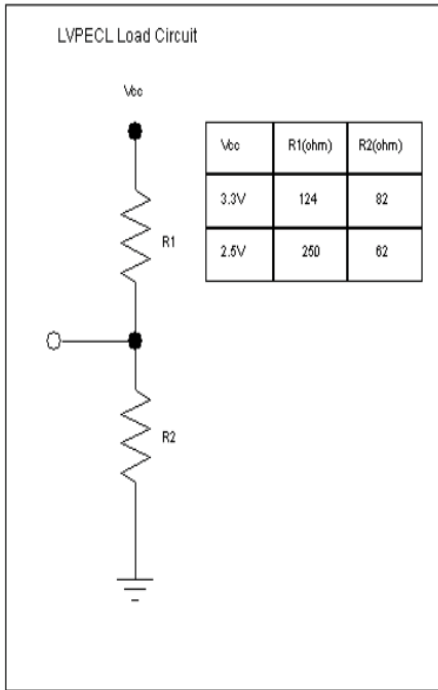

Maximum Soldering Conditions

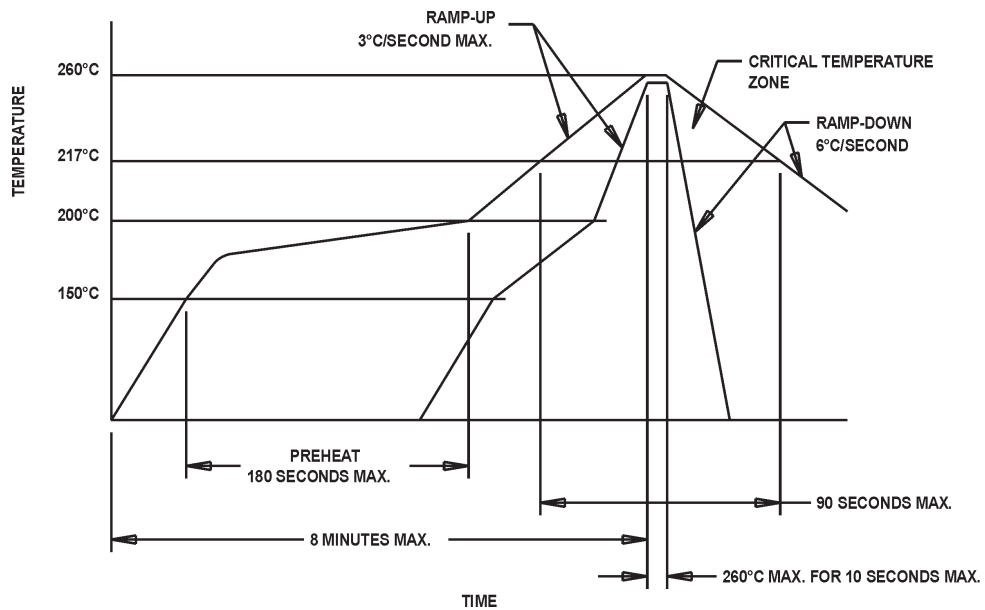

Parameter	Symbol	Min.	Typ.	Max.	Units	Conditions/Notes
Frequency Range	F	10 1.5		1400 200	MHz MHz	LVPECL, LVDS, CML CMOS
Operating Temperature	T _A	See How to order			°C	
Storage Temperature	T _{STG}	-55		+125	°C	
Frequency Stability		See how to order			ppm	
Frequency Tolerance at +25°C		-5.0		+5.0	ppm	See Note 1
Frequency Vs. Aging		-2.0 -1.0		+ 2.0 + 1.0	ppm ppm	1 st year Thereafter(per year).
Frequency Vs. Supply Voltage			± 0.5		ppm	5% voltage variation
Frequency Vs. Reflow			± 0.80		ppm	2 reflows max.
Frequency Vs. Load			± 0.5		ppm	5% supply voltage variation
Operating Voltage	V _{cc} /V _s /V _{dd}	3.135 2.375 1.71	3.3 2.5 1.8	3.465 2.625 1.89	V V V	
Operating Current	I _{cc}			130 110 120 100	mA mA mA mA	LVPECL LVDS CML CMOS
Rise/Fall Time	Tr/Tf			1.0 8	ns ns	PECL, LVPECL, LVDS CMOS
Logic "1" Level	V _{OH}	V _{CC} -1.02 90% V _{dd}			V V	LVPECL CMOS
Logic "0" Level	V _{OL}			V _{CC} -1.63 10% V _{dd}	V V	LVPECL CMOS
Common Mode Output Voltage	V _{cm}		1.2		V	LVDS
Symmetry (Duty Cycle)		45 45 45		55 55 55	% % %	@ 50% V _{dd} (CMOS) @ 50% of waveform (LVPECL) @ 1.25 V (LVDS)
Output Voltage Level		0.7	0.95	1.2	V _{p-p}	CML
Tuning Range		± 5			ppm	VCTCXO only. See Note 2.
Output Skew			20 15 20		ps ps ps	LVPECL CML LVDS
Output Load		50 ohm to (V _{CC} -2V) VDC 100 ohm Differential				See Note 3 LVPECL LVDS, CML
		15			pF	CMOS
Enable/Disable Function		80%		0.5 0.5	V V	Outputs enabled Outputs disabled Outputs enabled Outputs disabled
Phase Noise (Typical)	10 Hz	100 Hz	1 kHz	10 kHz	100 kHz	Offset from carrier
@ 622.080 MHz (LVPECL)	-60	-90	-120	-127	-133	dBc/Hz
@ 100.000 MHz (HCMOS)	-73	-97	-123	-131	-136	dBc/Hz
@ 50.000 MHz (HCMOS)	-80	-102	-130	-137	-141	dBc/Hz
Jitter	Phase jitter	0.1ps (Typical)@Integrated,Bandwidth 12KHz to 20MHz ,RMS				
	Random period jitter	3.0ps (Typical)@Integrated,Bandwidth 10KHz to 1MHz ,RMS				
	Pk to Pk jitter	20.0ps (Typical)				
Environmental	Shock	Per MIL-STD-202, Method 213, Condition C				
	Vibration	Per MIL-STD-202, Methods 201 & 204				
	Solderability	Per EIAJ-STD-002				
	Hermeticity	1 X 10 ⁻⁸ atm cc/sec of helium (Crystal only)				
	Thermal Shock	Per MIL-STD-883, Method 1011, Condition A				
	Thermal Cycle	Per MIL-STD-883, Method 1010, Condition B				

Note 1: Standard ±5ppm(Max),other frequency tolerance,pls factory

Note 2: Contact factory for other Tuning Range options.

Note 3: See Load Circuit Diagram.

Table II - Class R/V/S , Screening (100%)

Test - Inspection	Test Method – Condition
Nondestructive Bond Pull	MIL-STD-883, Method 2023
Internal Visual	MIL-STD-883, Method 2017, Level S
Stabilization Bake (Prior to Seal) <u>1/</u>	MIL-STD-883, Method 1008, Condition C (+150 °C), 48 hours minimum
Thermal Shock	MIL-STD-883, Method 1011, Condition A
Temperature Cycling	MIL-STD-883, Method 1010, Condition B
Constant Acceleration	MIL-STD-883, Method 2001, Condition A Y ₁ axis only (5000 G)
Seal (Fine and Gross Leak)	MIL-PRF-55310, Para. 4.8.2.2.2
Particle Impact Noise Detection (PIND)	MIL-STD-883, Method 2020, Condition A
Radiographic Inspection	MIL-STD-883, Method 2012, Class S
Electrical Tests: Record all measurements. Input Current Output Frequency Output Voltage Levels Output Rise & Fall Times Output Duty Cycle	Nominal Supply Voltage, Specified load, +23 °C MIL-PRF-55310, Para. 4.8.5 MIL-PRF-55310, Para. 4.8.6 MIL-PRF-55310, Para. 4.8.21.3 MIL-PRF-55310, Para. 4.8.22 MIL-PRF-55310, Para. 4.8.23
Burn-in (load)	+125 °C, Nominal Supply Voltage and Burn-in load, 320 Hours Minimum
Electrical Tests: Record all measurements. Input Current Output Frequency Output Voltage Levels Output Rise & Fall Times Output Duty Cycle	Nominal and Extreme Supply Voltages, Specified load, +23 °C and operating temperature extremes, MIL-PRF-55310, Para. 4.8.5 MIL-PRF-55310, Para. 4.8.6 MIL-PRF-55310, Para. 4.8.21.3 MIL-PRF-55310, Para. 4.8.22 MIL-PRF-55310, Para. 4.8.23

1/ Vacuum bake and maintain oscillators in dry nitrogen per MIL-PRF-55310.

Table III - Class B/M Screening (100%)

Test - Inspection	Test Method – Condition
Nondestructive Bond Pull	MIL-STD-883, Method 2023
Internal Visual	MIL-STD-883, Method 2017, Level B
Stabilization Bake (Prior to Seal) <u>1/</u>	MIL-STD-883, Method 1008, Condition C (+150 °C), 24 hours minimum
Temperature Cycling	MIL-STD-883, Method 1010, Condition B
Constant Acceleration	MIL-STD-883, Method 2001, Condition A Y ₁ axis only (5000 G)
Seal (Fine and Gross Leak)	MIL-PRF-55310, Para. 4.8.2.2.2
Particle Impact Noise Detection (PIND)	MIL-STD-883, Method 2020, Condition A
Electrical Tests: Input Current Output Frequency Output Voltage Levels Output Rise & Fall Times Output Duty Cycle	Nominal Supply Voltage, Specified load, +23 °C Verify all parameters MIL-PRF-55310, Para. 4.8.5 MIL-PRF-55310, Para. 4.8.6 MIL-PRF-55310, Para. 4.8.21.3 MIL-PRF-55310, Para. 4.8.22 MIL-PRF-55310, Para. 4.8.23
Burn-in (load)	+125 °C, Nominal Supply Voltage and Burn-in load, 160 Hours Minimum
Electrical Tests: Input Current Output Frequency Output Voltage Levels Output Rise & Fall Times Output Duty Cycle	Nominal Supply Voltage, Specified load, +23 °C and verify frequency at temperature extremes. MIL-PRF-55310, Para. 4.8.5 MIL-PRF-55310, Para. 4.8.6 MIL-PRF-55310, Para. 4.8.21.3 MIL-PRF-55310, Para. 4.8.22 MIL-PRF-55310, Para. 4.8.23

1/ Vacuum bake and maintain oscillators in dry nitrogen per MIL-PRF-55310.